

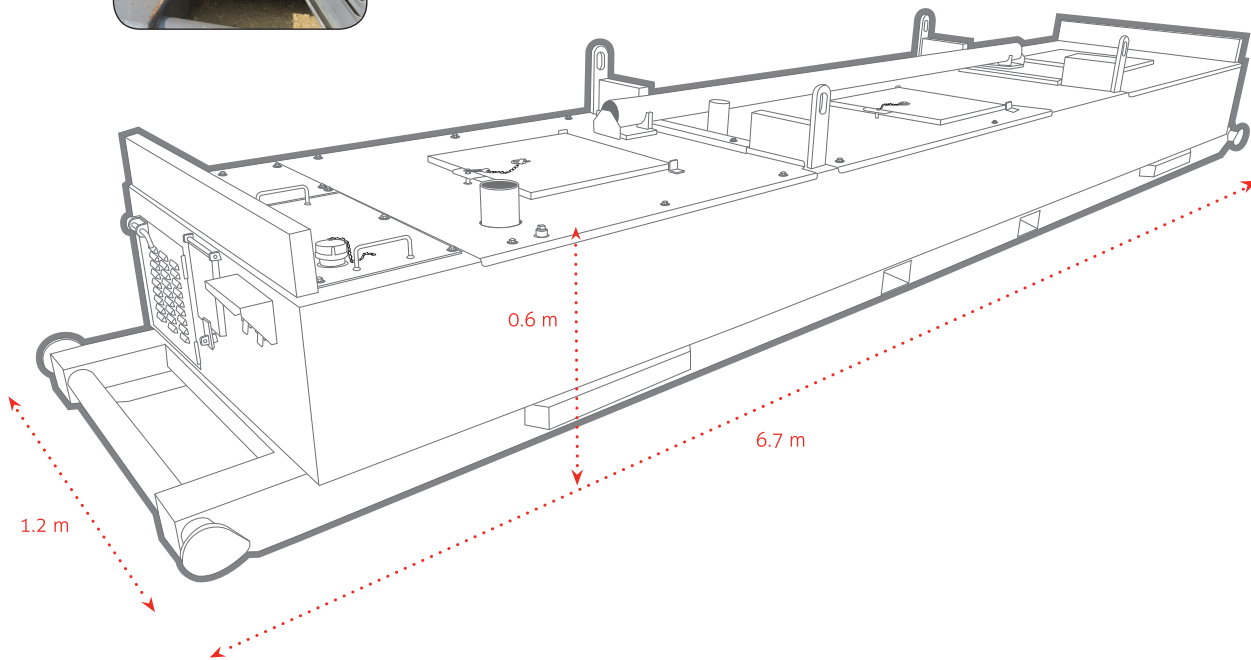

SANTEK

Ketek's Santek Tank prevents seepage of sewage into the ground formation and water aquifer. It is easy to use and provides for safe containment of grey water and sewage.



SEWAGE WASTE

Features:

2,800 L

- Diesel fired burner
- 110 Volt
- Exhaust stack

3,300 L

- Tank heater (optional)
- Air vent
- Approved by Alberta Municipal Affairs and B.C. Chief Environmental Health Officer

Notes: CSA Approved

Dimensions:

2,800 L

- Capacity 2,800 L (739 US Gal)
- L 6.7 m (22')
- W 1.2 m (4')
- H 0.6 m (2')
- Weight 1,360 kg (3,000 lbs)

3,300 L

- Capacity 3,300 L (871 US Gal)
- L 6.7 m (22')
- W 1.2 m (4')
- H 0.6 m (2')
- Weight 1,360 kg (3,000 lbs)