

# CYCLONATOR INCINERATOR CY-2020-A-FA CY-2050-A-FA



ENVIRONMENTALLY  
FRIENDLY



IDEAL FOR REMOTE  
CAMPS & COMMUNITIES



EASY TO OPERATE  
AND MAINTAIN



Ketek's Forced Air incinerators destroy solid waste (Types 1-2-3) efficiently and reduce the risk of contamination to the environment.

They're safe, environment friendly and reduce greenhouse gas emissions (GHG) when compared with many other waste disposal options.



Results Driven.

**KETEK**  
GROUP

# Cyclonator Incinerators

## CY-2020-A-FA, CY-2050-A-FA

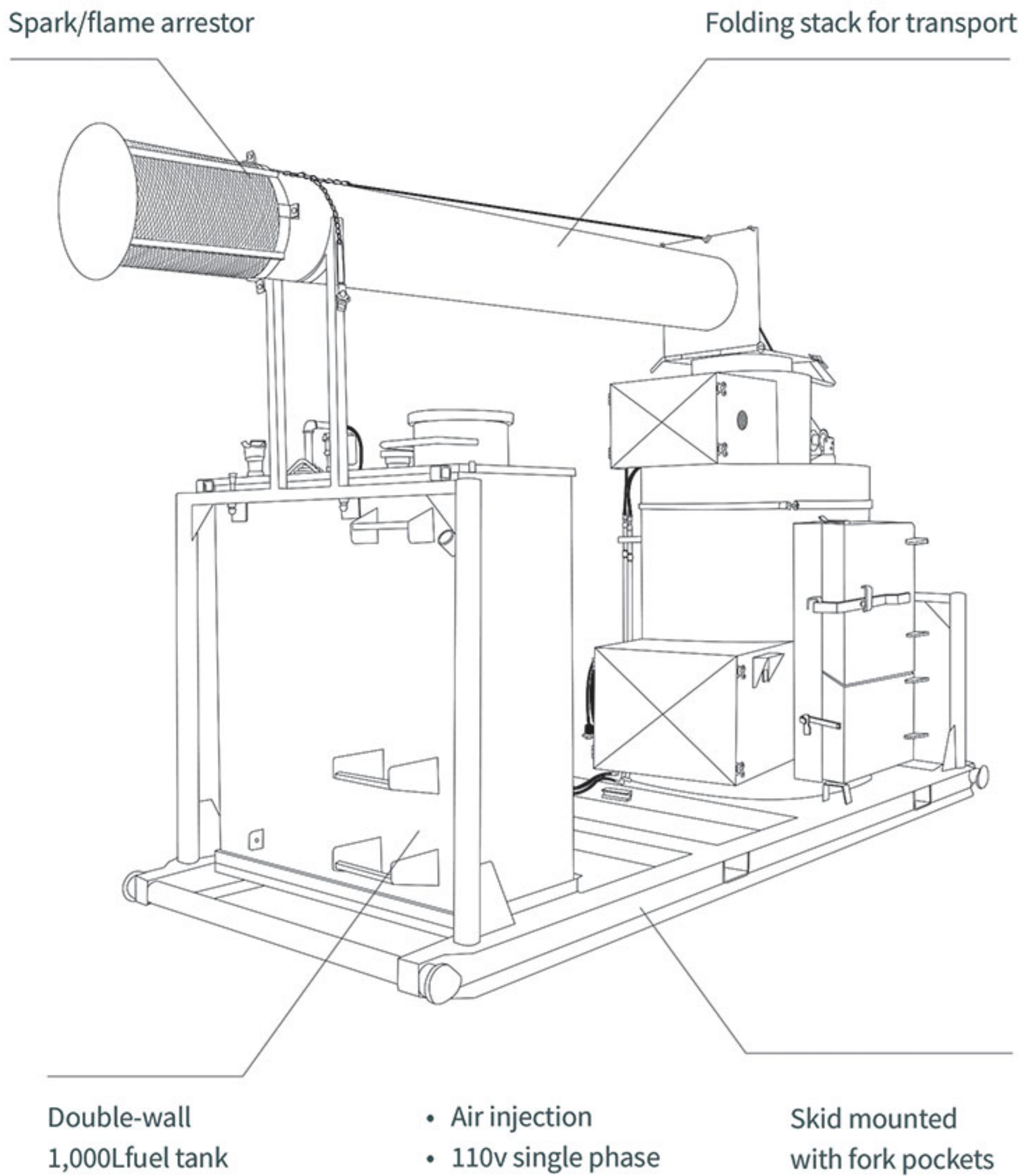

### Diesel fired



The CY-2020-A-FA burns approx. 0.6 m<sup>3</sup> (50 kg/hr)

The CY-2050-A-FA burns approx. 1.4 m<sup>3</sup> (75 kg/hr)



Propane or natural gas upon request.



Ketek proprietary fuel saver option



Continuous run cold weather package

### Dimensions (Assembled)

#### CY-2020-A-FA

- L 3.65 m (12')
- W 1.52 m (5')
- H 2.6 m (8' 9")
- Weight 3,200 kg (7,055 lbs)

### Dimensions (Assembled)

#### CY-2050-A-FA

- L 4.6 m (15')
- W 1.83 m (6')
- H 3.14 m (10' 4")
- Weight 4,800 kg (10,582 lbs)



### Contact Ketek

855-447-5050  
Info@ketek.ca

Visit  
ketek.ca